

MGCH-2 AC Magnetic Field Sensor

High Sensitivity AC Magnetic Field Sensor

The **MGCH-2** is the lowest noise, highest sensitivity single axis AC magnetic field sensor available for the measurement of sub radio frequency fields. Because of its innovative design, the **MGCH-2** amplitude response is insensitive to the frequency of the field over its 10 Hz to 100 kHz frequency band. Accuracy at 10 kHz is 0.1 dB, and the amplitude response stays within 2 dB peak-to-peak over the bandwidth.

The **MGCH-2**'s superior low noise performance is achieved by an optimum matching of the sensor preamplifier noise characteristics with the sensor coil properties. Its amplitude insensitivity to the magnetic field frequency over its bandwidth is accomplished by an innovative low noise current amplifier design.

The basic sensing element is a rod shaped induction coil with a ferromagnetic core. The core characteristics and winding parameters were carefully selected through computer optimization to match the noise characteristics of a custom designed low noise current preamplifier. This circuit topology produces an overall sensor transfer function that resembles a high pass filter with a corner frequency equal to $L/2\pi R$ where L is the coil inductance and R is the coil resistance. Beyond this frequency, the sensor amplitude is directly proportional to the magnetic field magnitude and insensitive to the field's frequency up to the coil's natural frequency.

The preamplifier is integrated with the sensing element in a cylindrical package that shields the coil from electrostatic fields while allowing the magnetic field to be accurately measured.

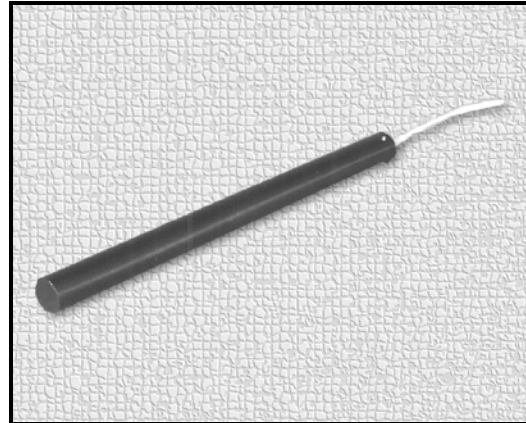

The **MGCH-2** output is a high level signal that can be safely transmitted through a cable connecting it to signal conditioning equipment without the introduction of additional noise. The SAM-3 portable signal conditioner was specifically designed by MEDA to provide power to and signal condition the MEDA series of AC magnetic field sensors.

Features

- ❑ Wide Bandwidth: 10 Hz to >100 kHz.
- ❑ Very Low Noise: $10\text{fT}/\sqrt{\text{Hz}}$ @ 1 kHz.
- ❑ High Accuracy: 0.1 dB @ 10 kHz, 2dB p-p over bandwidth.
- ❑ Response Insensitive to Signal Frequency over its Bandwidth.
- ❑ Low Power: 390 milliwatts nominal.

ZYKANG

深圳众裕康科技有限公司
Shenzhen Zhong Yu Kang Technology Co., Ltd

联系人：曾祥满 手机：13632925349 QQ：812401203 电话：0755- 28896837

地址：深圳市龙岗区沙平北路111号6008 网址：www.zykang.cn 邮箱：zykang2021@163.com

SPECIFICATIONS

Output

<i>Field Range</i>	800 nT peak-to-peak
<i>Voltage Range</i>	20 Volts peak-to-peak

Transfer Function

<i>Scale Factor</i>	25 mV/nT
<i>Accuracy</i>	0.1 dB @ 10 kHz, 2dB peak-to-peak over bandwidth
<i>Frequency Response (3dB point)</i>	10 Hz to >100 kHz

Noise (pT/√Hz)

10 Hz	2.5
100 Hz	0.1
1 kHz	0.01
10 kHz	0.004
100 kHz	0.003

Power Requirements

<i>Input Voltage</i>	±(12 to 18 VDC)
<i>+V Current Consumption</i>	13 mA nominal
<i>-V Current Consumption</i>	13 mA nominal

Physical

<i>Size</i>	13" L x 1.0" D
<i>Weight</i>	25.2 oz. (0.715 Kg)
<i>Cable Length</i>	20 feet
<i>Connector</i>	LEMO FGG.1B.306.CLCD 72

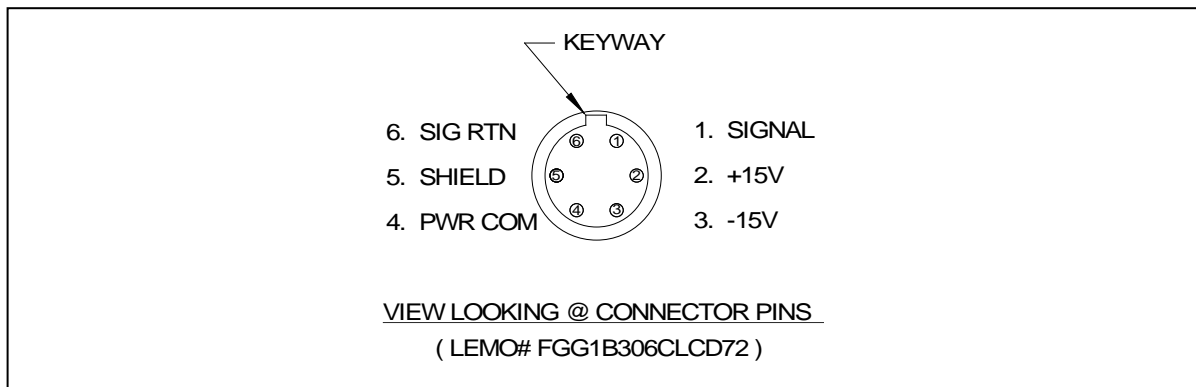

联系人：曾祥满 手机：13632925349 QQ：812401203 电话：0755- 28896837

深圳众裕康科技有限公司 地址：深圳市龙岗区沙平北路111号6008 网址：www.zykang.cn 邮箱：zykang2021@163.com
Shenzhen Zhong Yu Kang Technology Co., Ltd